

A系列外形尺寸图 A SERIES OUTLINE DIMENSION DRAWING

A系列外形尺寸图 A SERIES OUTLINE DIMENSION DRAWING

20A-FVA-19外形图  
20A-FVA-19 Outline Drawing

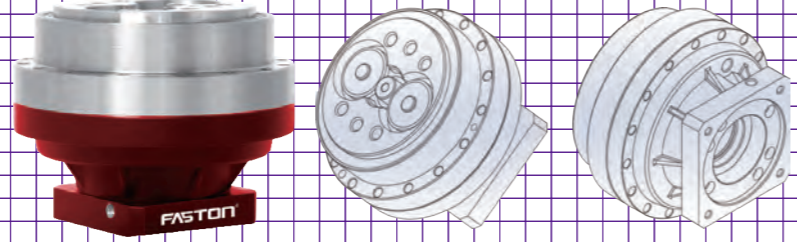

40A-FVA-19外形图  
40A-FVA-19 Outline Drawing

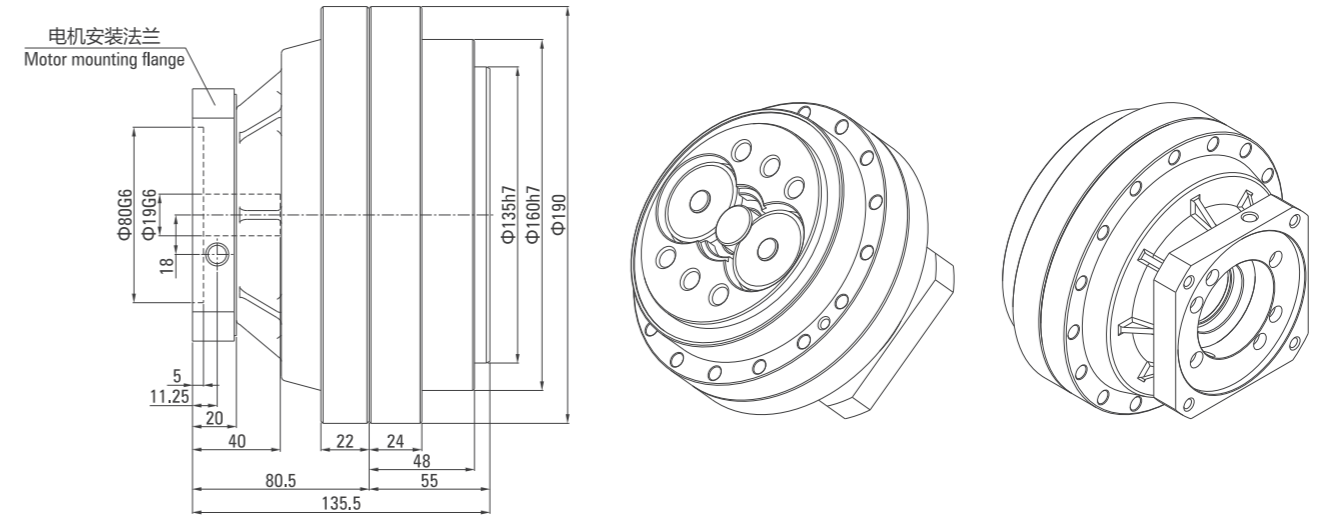
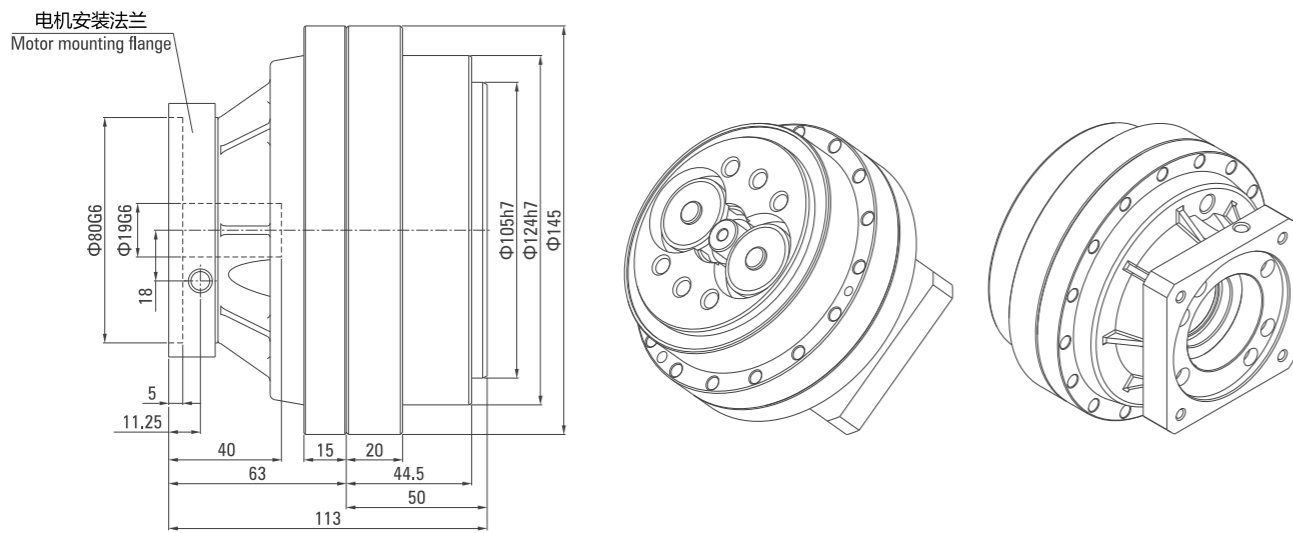
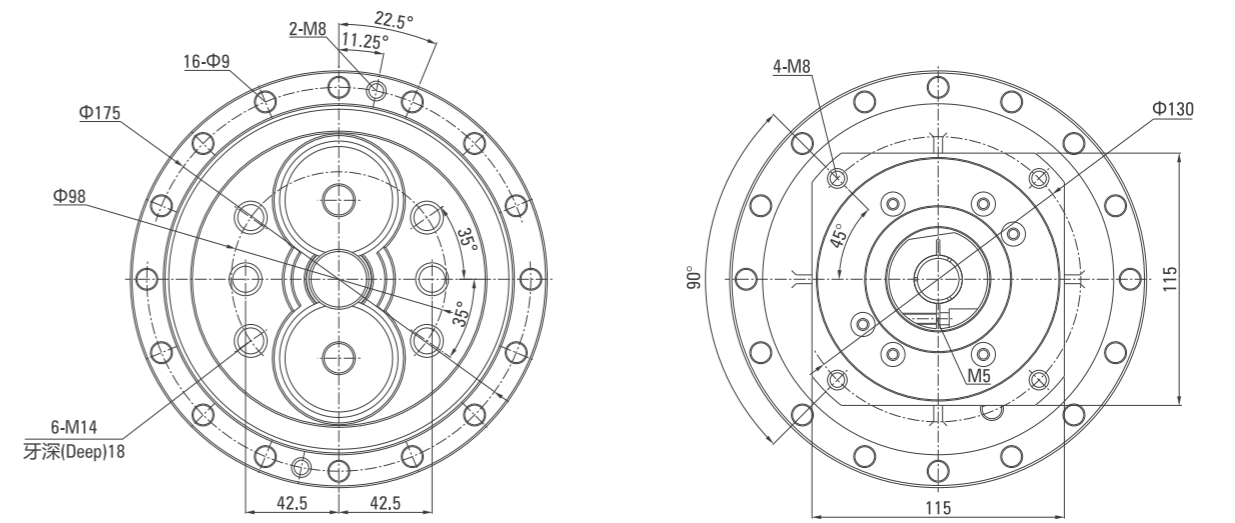
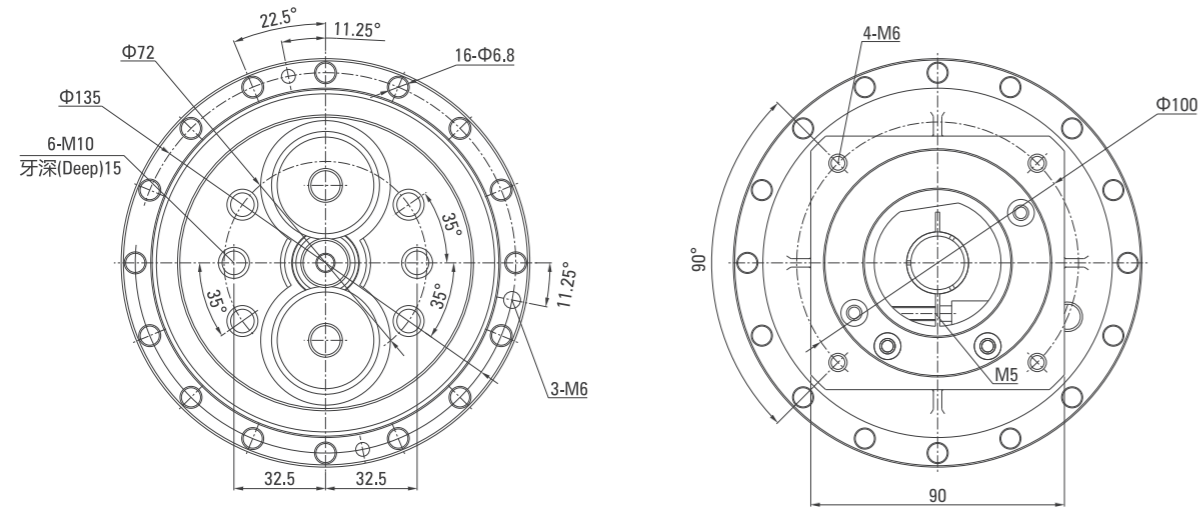
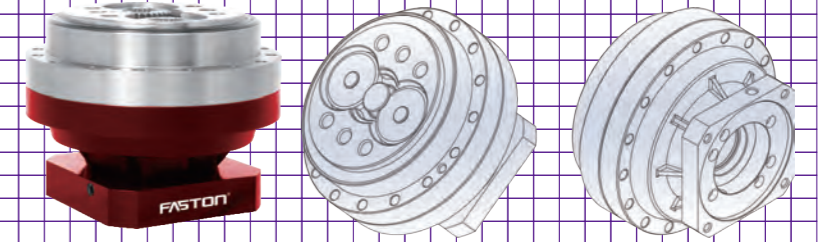

说明Note:

- 1.本图适用电机轴: <math>\leq 19 \times 40L</math>; 电机轴用锁紧器锁紧; This figure applies to the motor shaft: <math>\leq 19 \times 40L</math>; motor shaft lock use locker;
- 2.电机安装法兰依电机型号提供; Motor mounting flange according to motor model;

说明Note:

- 1.本图适用电机轴: <math>\leq 19 \times 40L</math>; 电机轴用锁紧器锁紧; This figure applies to the motor shaft: <math>\leq 19 \times 40L</math>; motor shaft lock use locker;
- 2.电机安装法兰依电机型号提供; Motor mounting flange according to motor model;

A系列外形尺寸图 A SERIES OUTLINE DIMENSION DRAWING

A系列外形尺寸图 A SERIES OUTLINE DIMENSION DRAWING

477/478

40A-FVA-24外形图  
40A-FVA-24 Outline Drawing

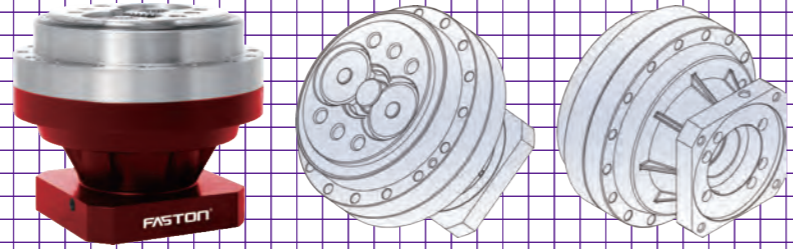

80A-FVA-24外形图  
80A-FVA-24 Outline Drawing

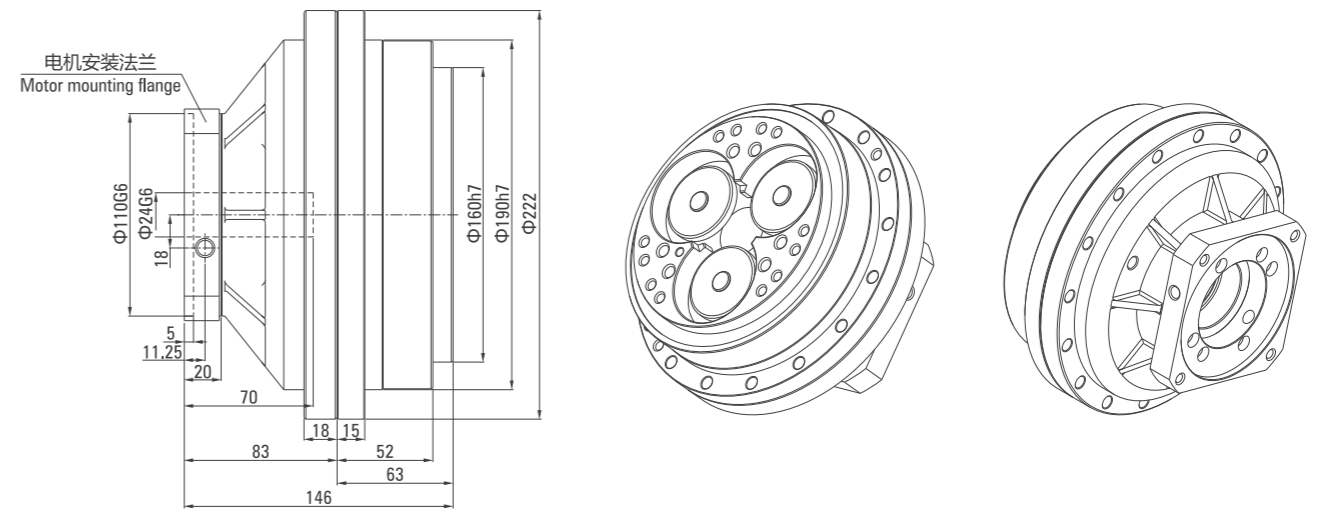
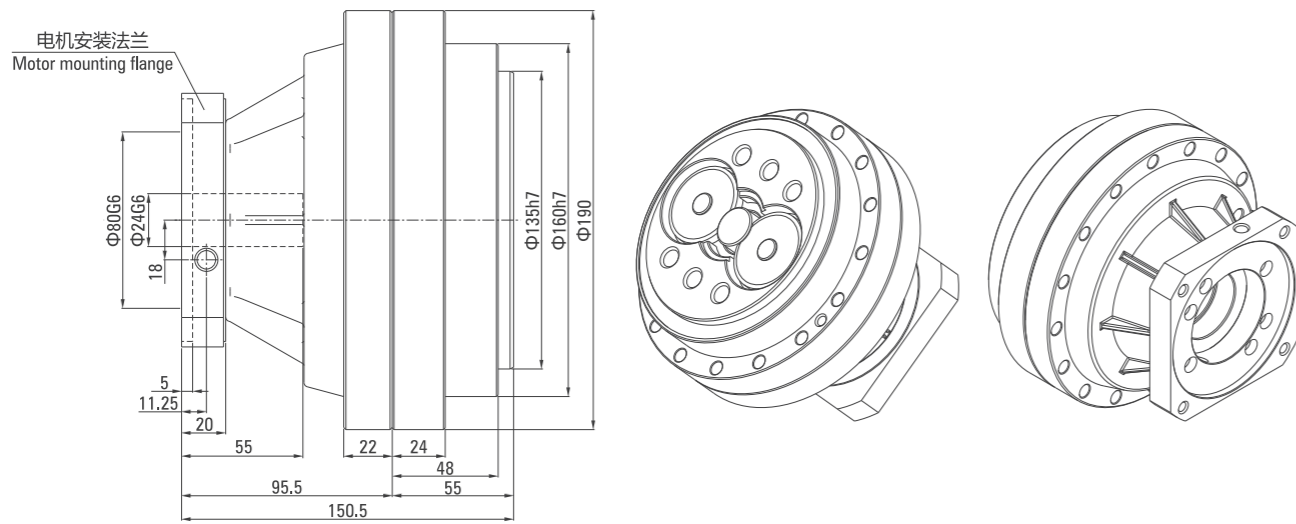
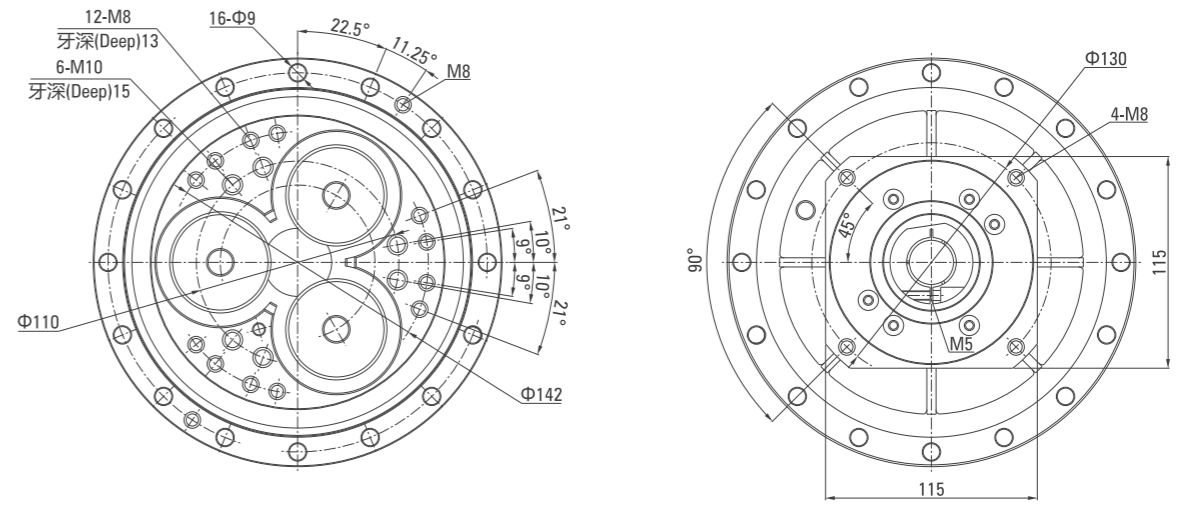
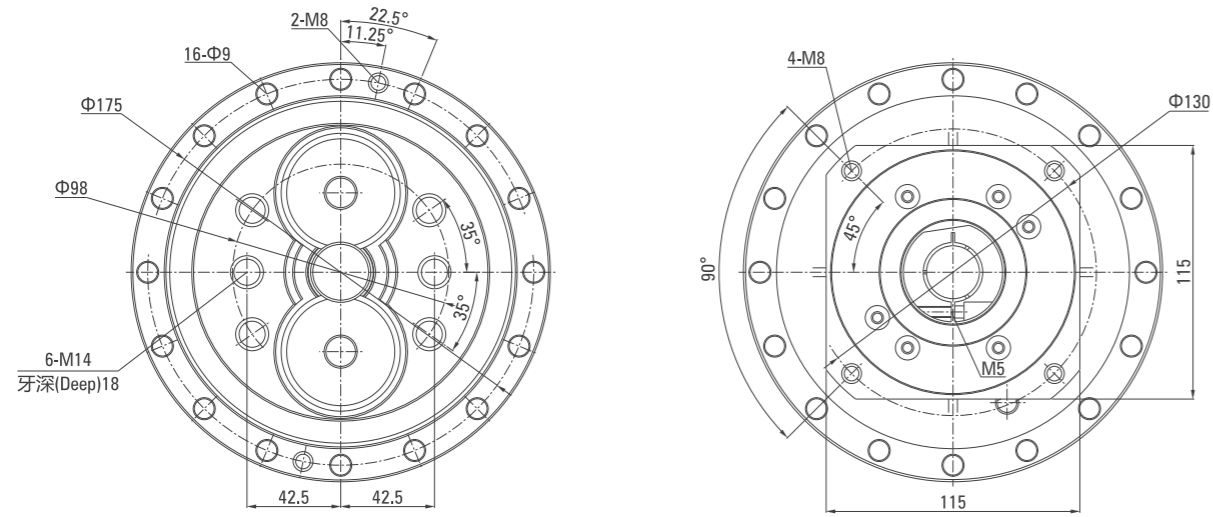
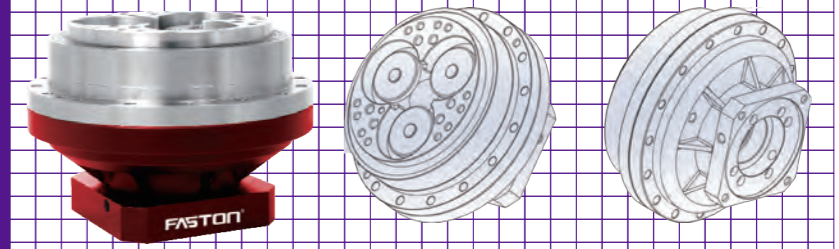

说明Note:

- 1.本图适用电机轴:  $\leq 24 \times 55L$ ; 电机轴用锁紧器锁紧; This figure applies to the motor shaft:  $\leq 24 \times 55L$ ; motor shaft lock use locker;
- 2.电机安装法兰依电机型号提供。Motor mounting flange according to motor model.

说明Note:

- 1.本图适用电机轴:  $\leq 24 \times 70L$ ; 电机轴用锁紧器锁紧; This figure applies to the motor shaft:  $\leq 24 \times 70L$ ; motor shaft lock use locker;
- 2.电机安装法兰依电机型号提供。Motor mounting flange according to motor model.

A系列外形尺寸图 A SERIES OUTLINE DIMENSION DRAWING

80A-FVA-35外形图  
80A-FVA-35 Outline Drawing

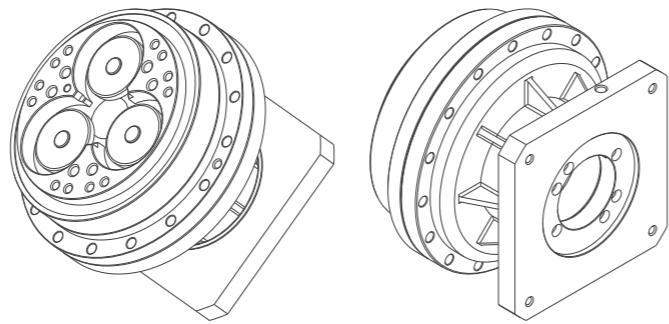
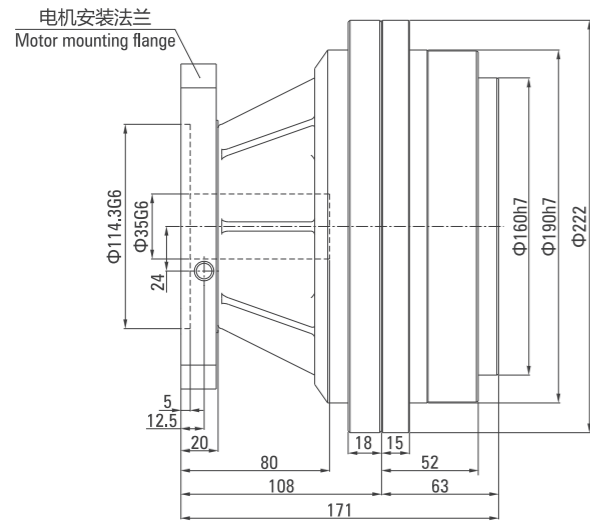
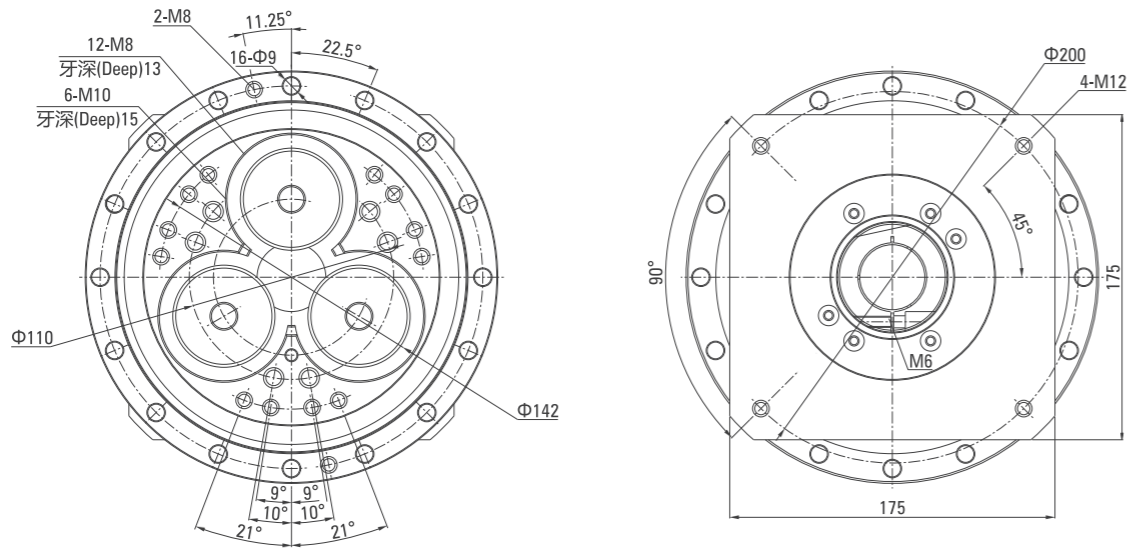
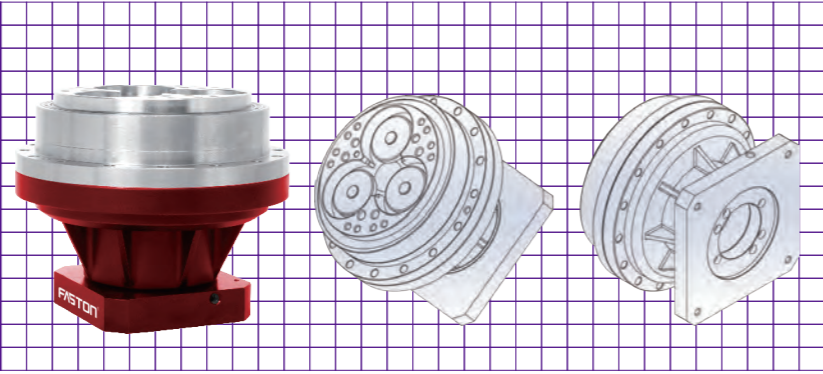

说明 Note:

- 1.本图适用电机轴:  $\leq 35 \times 80L$ ; 电机轴用锁紧器锁紧; This figure applies to the motor shaft:  $\leq 35 \times 80L$ ; motor shaft lock use locker.
- 2.电机安装法兰依电机型号提供。Motor mounting flange according to motor model.

A系列减速机安装图 A SERIES INSTALLATION DRAWING

FVA系列减速机  
FVA Series Reducer

FVA系列减速机安装示例  
FVA Series Reducer Installation Example

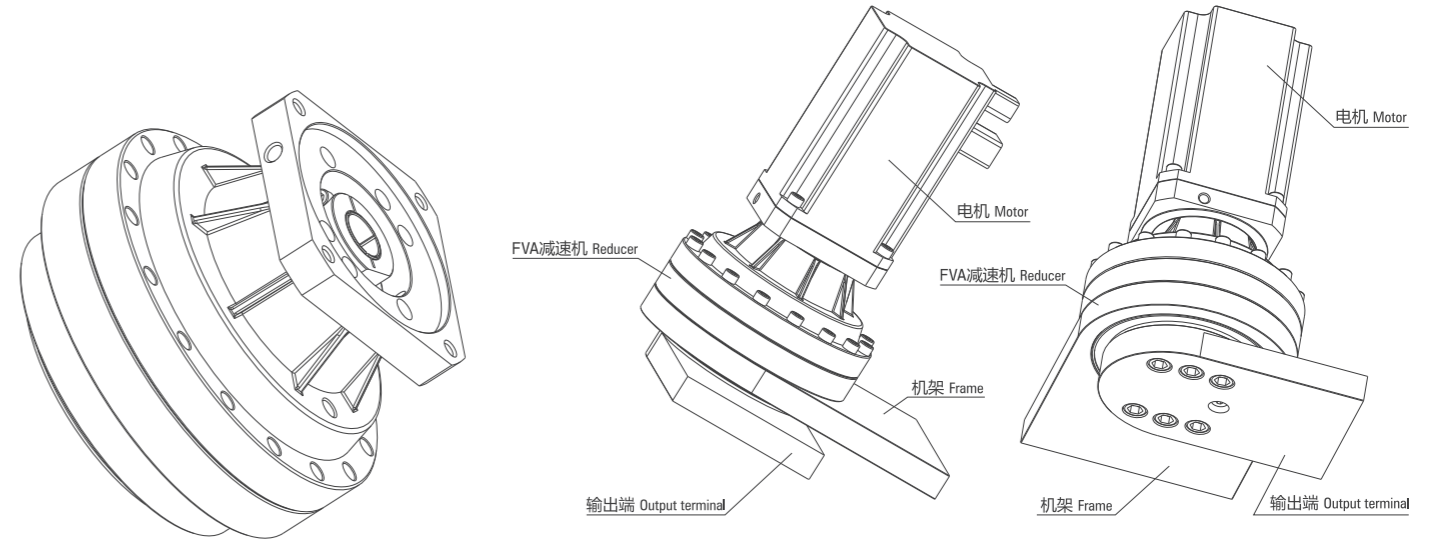

FVA系列减速机安装拆解示意图 FVA Series Mounting Schematic Diagram (Disassemble Diagram)

